

Low Tension Transducer



FEATURES

- Capacity range: 20, 50, 100, 200, and 500 lb (9.1, 22.7, 45.4, 90.7, and 227 kg)
- Single bolt mounting with visual alignment marks for direct measurement of resultant force
- Repeatability better than 0.02% rated output
- Wide range of operating tensions (rangeability)
- Minimal deflection allows high operating speeds
- Factory calibrated for minimum start-up time
- Stainless steel construction with high overload capability

DESCRIPTION

LTT technology combines precision strain gage force transducers with dead shaft mounting options to produce the highest accuracy web tension measurement systems available. LTT series transducers, developed for low force web tension applications, incorporate a differential bending beam design with a full Wheatstone Bridge strain gage configuration. This design provides stable, accurate, and repeatable measurement over a wide range of operating tensions while virtually eliminating temperature drift.

All LTT capacities are equipped with mechanical overload protection.

Available with a mounting configuration for dead shaft applications (with horizontal or vertical support surfaces), the LTT can be

rotated to measure the resultant tension force, not just a component of the force.

Factory calibration, with closely matched output signals, eliminates field calibration and costly recalibration after the initial set-up. Zero and span settings remain stable for tension forces at the low end of wide rangeability applications. The full bridge design (as opposed to half bridge) provides moderate accuracy when using a single transducer on one end of the roll.

APPLICATIONS

- Converting equipment
- Winders/unwinders
- Coaters
- Laminators
- Printing presses

CONFIGURATION

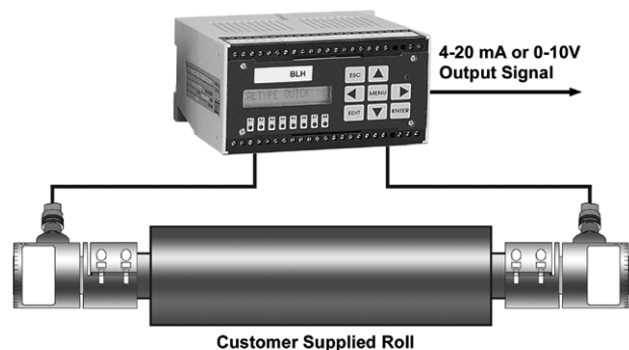
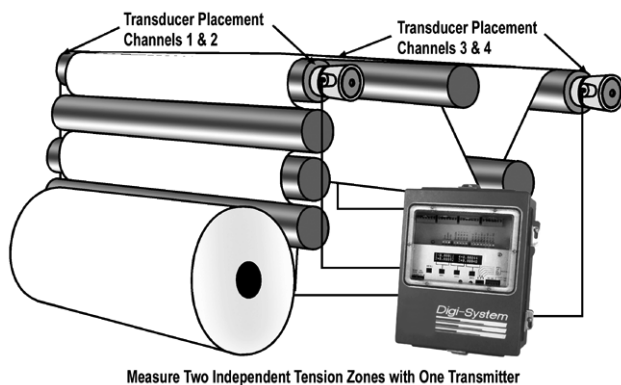

SPECIFICATIONS

Performance (% Rated Output)

Rated Capacity	20, 50, 100, 200, 500lb (9.1, 22.7, 45.4, 90.7, and 227kg)
Rated Output (RO)	2.000 mV/V \pm 0.25%
Nominal	
Repeatability	0.02% RO
Maximum Combined	0.05% RO
Error	
Zero Balance	5.0% RO
Creep (20 Minutes)	0.03% RO
Temperature Effects:	
Effect on Zero Balance	0.002% RO/°F (0.0036% RO/°C)
Effect on Rated Output	0.002% of reading/°F (0.0036% of reading/°C)

Electrical

Input Resistance	350 ohms \pm 3 ohms
Output Resistance	350 ohms \pm 3 ohms
Recommended Excitation	10Vac/dc
Maximum Excitation	15Vac/dc

Note: Transducer axis misalignment \pm 3° max

Note: Environmental sealing optionally available; may affect measured accuracy by 1 ounce or less

Note: Install Intrinsically safe systems with Drawing # 468872-1

Temperature

Operating Range	-40 to 220°F (-40 -105°C)
Compensated Range	+15 to 130°F (-10 to 65°C)

Overload Rating

Safe Load	200% rated capacity
Safe Side Load	100% rated capacity
Ultimate Load	300% (or better) rated capacity

Materials

All Load Cell Parts	stainless steel
Bendix Connector	cadmium plated aluminum

Deflection at Rated Capacity

LTT - 20 lb 0.0055 in.	LTT - 200 lb 0.0210 in.
LTT - 50 lb 0.0045 in.	LTT - 500 lb 0.0148 in.
LTT - 100 lb 0.0035 in.	

Approvals

FM (Factory Mutual)	3611 (Class I, II, 111; Div.1,2; Groups A-G)
CSA	C22.2 (Class I, 11,111; Div.1,2; Groups A-G)

OUTLINE DIMENSIONS - LTT WITH DEAD SHAFT ADAPTER

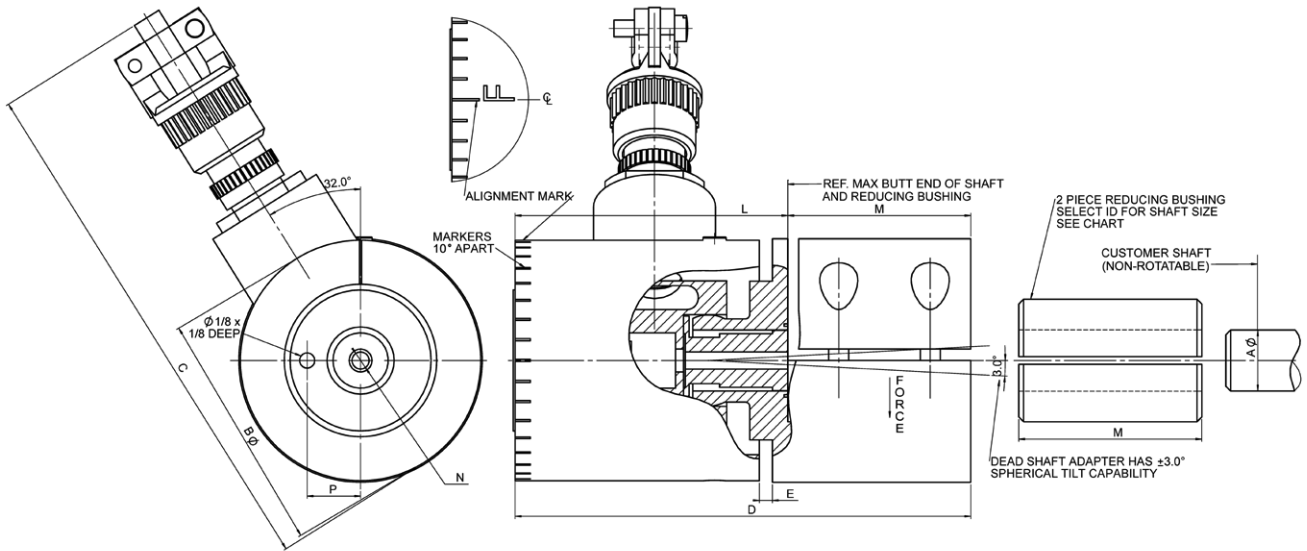

PART NAME	CAP (lbs)	A SHAFT (NOM)	BØ	C	D (MAX)	E	L (REF)	M	N	P
		1/2	1.97	4 3/8	3.75	0.11	2.25	1.50	1/2-20UNF-2B x 9/16 DEEP	0.438
LTT 20	20	5/8								
LTT 50	50	3/4								
LTT 100	100	7/8	3.47	5 29/32	5.68	0.16	3.68	2.00	5/8-18UNF-2B x 11/16 DEEP	0.750
		1								
		1 1/4								
LTT 200	200	1 1/2								
LTT 500	500	1 3/4	2							
		2								

NOTE:
1. ALL DIMENSIONS IN TABLE - IN INCHES.

CONNECTOR COLOR CODE

EXCITATION	GREEN (+)	C
	BLACK (-)	B
OUTPUT	WHITE (+)	D
	RED (-)	A

BLH is continually seeking to improve product quality and performance. Specifications may change accordingly.